



**ExTPro**

# DuraSpin ExTPro

**Installation Instructions**  
(Original Instructions)



# SENCO®

Verpa Senco BV  
Pascallaan 88  
8218 NJ Lelystad  
The Netherlands  
EMEA: [www.senco.eu](http://www.senco.eu)

**NFE2WB • May 30, 2017**

# INSTALLATION GUIDE

## Installation guide

To Install a DuraSpin collated screw fastening system, adjust the mounting bracket to the correct position for your tool type, corded or cordless. Place the rear of the DuraSpin housing into the circular mounting bracket.

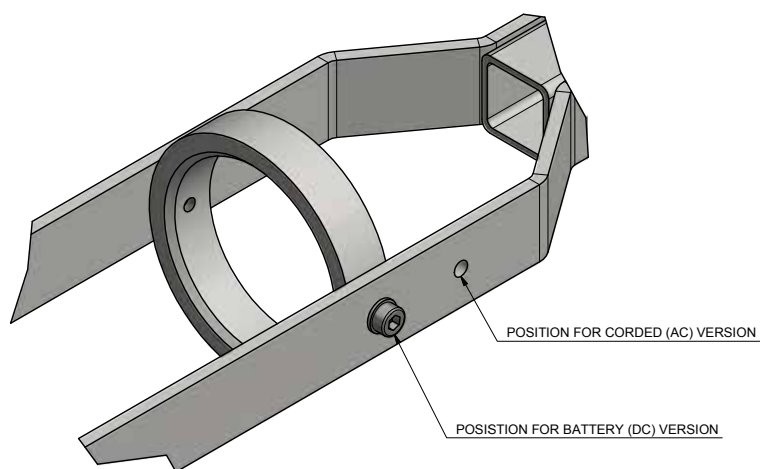

Position the front of the DuraSpin tool centrally into the front mounting bracket. Align items 4 with the recess in the DuraSpin tool housing and tighten cap head screws.

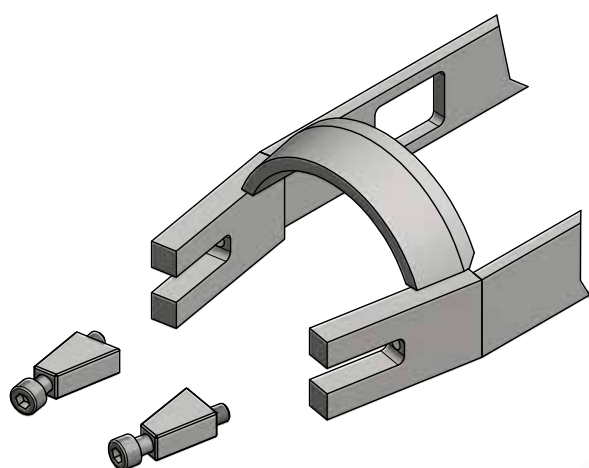

# PARTS DIAGRAM

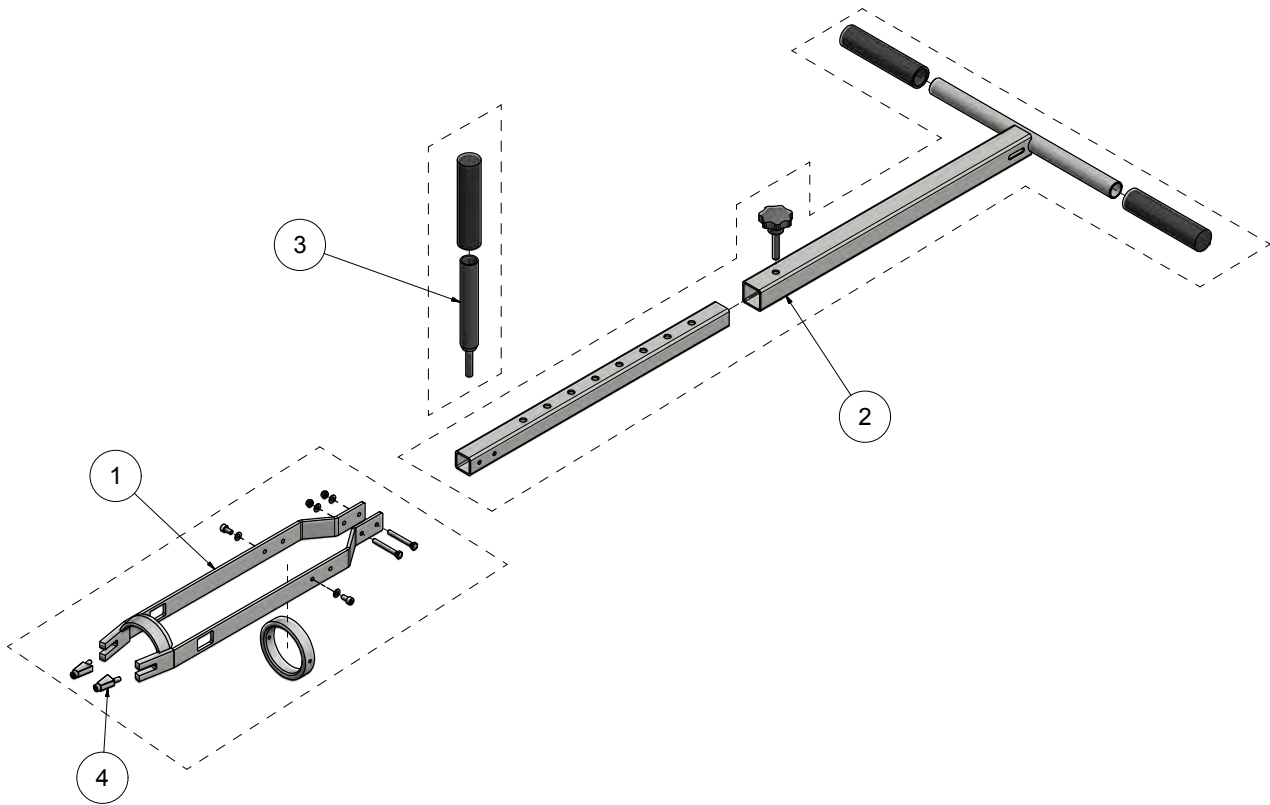

NUMBER	PARTNUMBER	DESCRIPTION
1	WB0062EU	Mounting bracket
2	WB0063EU	Extention pole + handle
3	WB0064EU	Handgrip extention
4	WB0065EU	Mounting blocks