

SENCO[®] *SPRING BALANCER*

OPERATING INSTRUCTIONS



© 2014 by Senco Brands, Inc.

Verpa Senco B.V.
Pascallaan 88
8218 NJ Lelystad
www.senco-emea.com

Date: 06-03-2014

Read this manual before use



CAUTION



Prohibition



Install into a closed and solid fixture.



This hole was used for hanging, do not lock tightly for wider operation direction.



Always attached a secondary support cable or chain.



Take loading off before adjusting.

The + means the turning direction of increase capacity.

Only press the spring 1~3 cm to decrease capacity.

Loosen the screws and fasten the ball in a position of rope.

Loading the tool with the closed hook. Check the load before replacing the tool.



Temperature: $-10^{\circ}\text{C} \sim 50^{\circ}\text{C}$

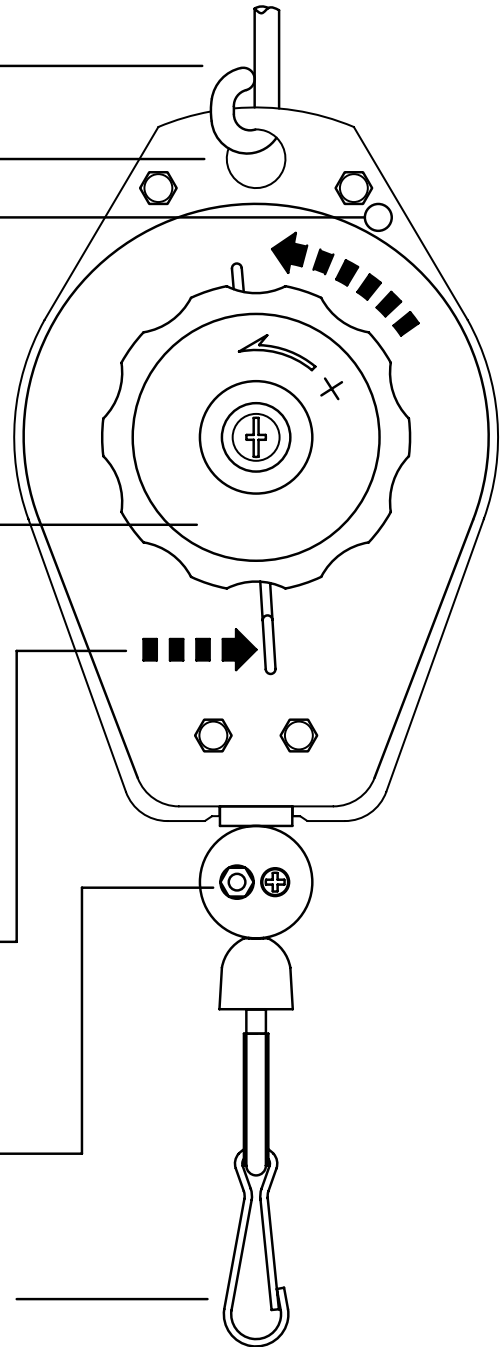

Read this manual before use

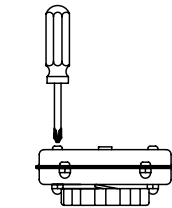
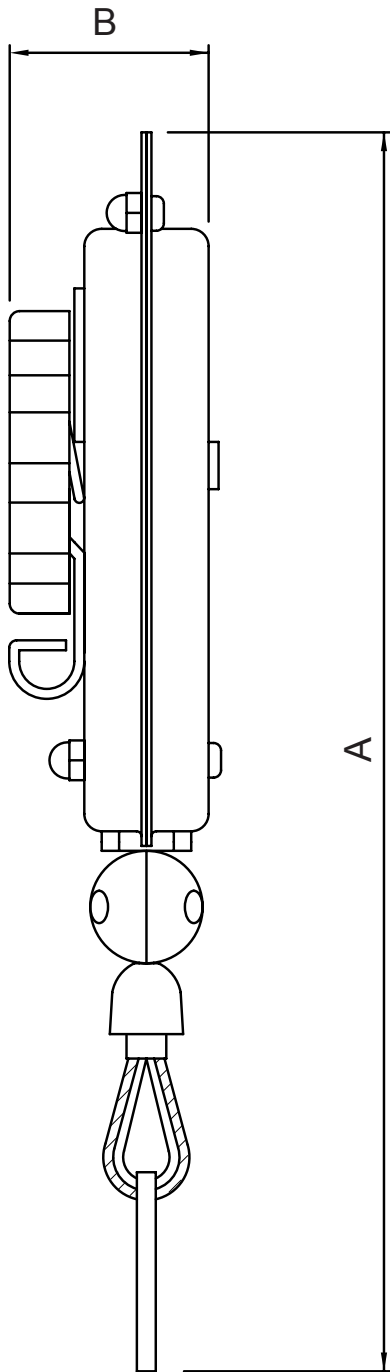

Prohibition of disassembly.

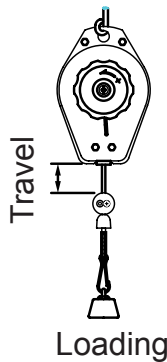

Don't twist and rub the cordage with cable during travel.
Don't load over its capacity.

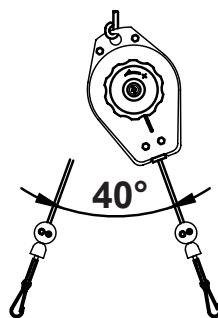

Large angle using will
debase the wire rope's life,
under $\pm 20^\circ$ is better.

DECLARATION OF CONFORMITY	KONFORMITÄTSERKLÄRUNG	CONFORMITEITSVERKLARING
<p>We of Senco Brands, BV. Geurdeland 17E 6673 BR Andelst, The Netherlands</p> <p>in accordance with the following directive(s): Machine Directive 2006/42/EC</p> <p>declare under our sole responsibility that:</p> <p>Model(s): Spring balancer 4001000, 4001001 is in conformity with the applicable essential health and safety requirements of the following documents: EN792-1:2000+A1:2008, EN792-3:2000+A1:2008 EN792-4:2000+A1:2008, EN792-6:2000+A1:2008 EN792-7:2001+A1:2008, EN792-8:2001+A1:2008 EN792-9:2001+A1:2008, EN792-11:2001+A1:2008 EN792-12:2000+A1:2008, EN792-13:2000+A1:2008</p> <p>Signed by: Peter van der Wel Position: Director Place of DOC: Senco Brands, BV. Geurdeland 17E 6673 DR Andelst The Netherlands</p> <p>On Date: April 29, 2010</p>	<p>Wir von Senco Brands, BV. Geurdeland 17E 6673 BR Andelst, The Netherlands</p> <p>in Übereinstimmung mit den folgenden Richtlinien: Maschinenrichtlinie 2006/42/EG</p> <p>erklären in alleiniger Verantwortung, dass:</p> <p>Modell/Modelle: Spring balancer 4001000, 4001001 den geltenden Gesundheits- und Sicherheitsanforderungen entspricht, so wie sie in den folgenden Dokumenten festgehalten werden: EN792-1:2000+A1:2008, EN792-3:2000+A1:2008 EN792-4:2000+A1:2008, EN792-6:2000+A1:2008 EN792-7:2001+A1:2008, EN792-8:2001+A1:2008 EN792-9:2001+A1:2008, EN792-11:2001+A1:2008 EN792-12:2000+A1:2008, EN792-13:2000+A1:2008</p> <p>Unterschrieben von: Peter van der Wel Position: Director Ort der Erklärung: Senco Brands, BV. Geurdeland 17E 6673 DR Andelst The Netherlands</p> <p>Ursprüngliche Herausgabe: 29. April, 2010</p>	<p>Wij uit Senco Brands, BV. Geurdeland 17E 6673 BR Andelst, The Netherlands</p> <p>in overeenstemming met de volgende richtlijn(en): Machinerichtlijn 2006/42/EC</p> <p>verklaren onder onze eigen verantwoordelijkheid dat:</p> <p>Model(len): Spring balancer 4001000, 4001001 in overeenstemming is met de toepasselijke essentiële gezondheids- en veiligheidseisen van de volgende documenten: EN792-1:2000+A1:2008, EN792-3:2000+A1:2008 EN792-4:2000+A1:2008, EN792-6:2000+A1:2008 EN792-7:2001+A1:2008, EN792-8:2001+A1:2008 EN792-9:2001+A1:2008, EN792-11:2001+A1:2008 EN792-12:2000+A1:2008, EN792-13:2000+A1:2008</p> <p>Ondertekend door: Peter van der Wel Functie: Directeur Locatie van doc.: Senco Brands, BV. Geurdeland 17E 6673 DR Andelst The Netherlands</p> <p>Originele uitgave: 23 april 2010</p>
<p>DÉCLARATION DE CONFORMITÉ</p> <p>Nous, Senco Brands, BV. sis au Geurdeland 17E 6673 BR Andelst, The Netherlands</p> <p>conformément à la (aux) directive(s) suivante(s): Machine Directive 2006/42/EC</p> <p>déclarons, en vertu de notre responsabilité exclusive, ce qui suit :</p> <p>Modèle(s) : Spring balancer 4001000, 4001001 est conforme aux exigences essentielles applicables en matière de santé et de sécurité, telles que stipulées dans les documents ci-dessous : EN792-1:2000+A1:2008, EN792-3:2000+A1:2008 EN792-4:2000+A1:2008, EN792-6:2000+A1:2008 EN792-7:2001+A1:2008, EN792-8:2001+A1:2008 EN792-9:2001+A1:2008, EN792-11:2001+A1:2008 EN792-12:2000+A1:2008, EN792-13:2000+A1:2008</p> <p>Signé par : Peter van der Wel Poste : Directeur Lieu du document : Senco Brands, BV. Geurdeland 17E 6673 DR Andelst The Netherlands</p> <p>Version initiale : 23 avril 2010</p>	<p>YHDENMUKAISUUSVAKUUTUS</p> <p>Me Senco Brands, BV. osoitteesta Geurdeland 17E 6673 BR Andelst, The Netherlands</p> <p>seuraavien direktiivien mukaisesti: Konedirektiivi 2006/42/EY</p> <p>julistamme yksinomaisella vastuullamme, että:</p> <p>Malli(t): Spring balancer 4001000, 4001001 on seuraavien asiakirjojen soveltuvien olennaisten työsuojeluvuatomusten mukainen: EN792-1:2000+A1:2008, EN792-3:2000+A1:2008 EN792-4:2000+A1:2008, EN792-6:2000+A1:2008 EN792-7:2001+A1:2008, EN792-8:2001+A1:2008 EN792-9:2001+A1:2008, EN792-11:2001+A1:2008 EN792-12:2000+A1:2008, EN792-13:2000+A1:2008</p> <p>Allekirjoitus: Peter van der Wel Asema: Johtaja Antopaikka: Senco Brands, BV. Geurdeland 17E 6673 DR Andelst The Netherlands</p> <p>Alkuperäisjulkaisu: 23 huhtikuuta 2010</p>	<p>ERKLÆRING OM SAMSVAR</p> <p>Vi, Senco Brands, BV. med adresse Geurdeland 17E 6673 BR Andelst, The Netherlands</p> <p>erklærer i henhold til følgende direktiv(er): Maskindirektiv 2006/42/EF</p> <p>under vårt eneansvar at:</p> <p>modell(er): Spring balancer 4001000, 4001001 er laget i henhold til gjeldende grunnleggende bestemmelser for helse og sikkerhet i følgende dokumenter: EN792-1:2000+A1:2008, EN792-3:2000+A1:2008 EN792-4:2000+A1:2008, EN792-6:2000+A1:2008 EN792-7:2001+A1:2008, EN792-8:2001+A1:2008 EN792-9:2001+A1:2008, EN792-11:2001+A1:2008 EN792-12:2000+A1:2008, EN792-13:2000+A1:2008</p> <p>Underskrevet av: Peter van der Wel Stilling: Direktør Dokumentets sted: Senco Brands, BV. Geurdeland 17E 6673 DR Andelst The Netherlands</p> <p>Opprinnelig utstedt: april 23, 2010</p>